

Operating instructions

UNIVERSAL CUTTING MILL

PULVERISETTE 19

Valid starting with: 19.30X0/00500

Valid starting with: 19.31X0/00001

Valid starting with: 19.40X0/00001



Read the instructions prior to performing any task!

Translation of the original operating instructions



Certifications and CE conformity

Certification

Fritsch GmbH has been certified by the SGS-TÜV Saar GmbH.



An audit certified that Fritsch GmbH conforms to the requirements of the DIN EN ISO 9001:2015.

CE Conformity

The enclosed Conformity Declaration lists the guidelines the FRITSCH instrument conforms to, to be able to bear the CE mark.



Table of contents

1	Basic structure.....	7
2	Safety information and use.....	9
	2.1 Requirements for the user.....	9
	2.2 Scope of application.....	10
	2.2.1 Operating principle.....	10
	2.3 Obligations of the operator.....	11
	2.4 Information on hazards and symbols used in this manual...	11
	2.5 Device safety information.....	13
	2.6 Protective equipment.....	14
	2.6.1 Opening the cutting mill without mains connection.....	15
	2.7 Hazardous points.....	16
	2.8 Electrical safety.....	16
	2.8.1 Protection against restart.....	16
	2.8.2 Overload protection.....	16
3	Technical data.....	17
	3.1 Dimensions.....	17
	3.2 Weight.....	17
	3.3 Speed.....	17
	3.4 Operating noise.....	18
	3.5 Voltage.....	18
	3.6 Current consumption.....	19
	3.7 Power consumption.....	19
	3.8 Rotor torque.....	19
	3.9 Electrical fuses.....	20
	3.10 Material.....	20
	3.11 Final fineness.....	20
4	Installation.....	21
	4.1 Transport.....	21
	4.2 Unpacking.....	21
	4.3 Setting up.....	21
	4.4 Ambient conditions.....	21
	4.5 Fastening the Universal Cutting Mill.....	22
	4.6 Selecting and converting the funnels.....	22
	4.6.1 Selecting the funnel.....	22
	4.6.2 Converting from standard funnel to protected funnel.....	23
	4.6.3 Converting from protected funnel to standard funnel.....	24
	4.7 Electrical connection.....	24
	4.8 Set-up mode.....	25
5	Initial start-up.....	26
	5.1 Switching on.....	26
	5.2 Function check.....	26

5.3	Switching off.....	27
6	Using the device.....	28
6.1	Preparing a comminution.....	28
6.1.1	Opening the cutting mill.....	28
6.1.2	Inserting / changing the fixed knives.....	29
6.1.2.1	Installation position of the fixed knives.....	29
6.1.2.2	Installation position of the fixed knives with tungsten carbide cutting edge.....	30
6.1.3	Setting the gap width of the knives.....	30
6.1.4	Inserting / changing a rotor.....	31
6.1.5	Inserting / changing a sieve cassette.....	33
6.1.5.1	Selecting the sieve cassette.....	34
6.1.6	Closing the cutting mill.....	34
6.1.7	Checking if the rotor is turning freely.....	34
6.2	Comminution procedure with standard funnel.....	35
6.2.1	Using the plunger.....	35
6.3	Comminution procedure with the protected funnel.....	36
6.4	Overload of the cutting mill.....	36
6.5	Sample exhaust system with cyclone separator.....	37
6.5.1	High-performance cyclone separator.....	38
6.5.2	Small volume Cyclone separator.....	39
7	Cleaning.....	41
7.1	Housing.....	41
7.2	Cutting chamber.....	41
7.3	Funnel.....	42
7.3.1	Standard funnel (15).....	42
7.3.2	Protected funnel (24).....	42
7.3.2.1	Removing sample pusher (21).....	43
7.3.2.2	Removing the plunger (22).....	43
7.4	Collecting vessel.....	44
7.5	Cleaning the filter foam mat.....	44
7.6	Cleaning the labyrinth seal.....	44
7.7	Cleaning the labyrinth seal in the closing lid.....	46
8	Maintenance.....	48
9	Repairs.....	50
9.1	Checklist for troubleshooting.....	50
9.2	Error messages.....	51
10	Disposal.....	53
11	Guarantee terms.....	54
12	Exclusion of liability.....	56
13	Safety logbook.....	58

Table of contents

14	Index.....	60
----	------------	----

1 Basic structure



The PULVERISETTE 19 large is available only with the protected funnel (24).

The images used in the following operating manual show only the standard version of the PULVERISETTE 19.

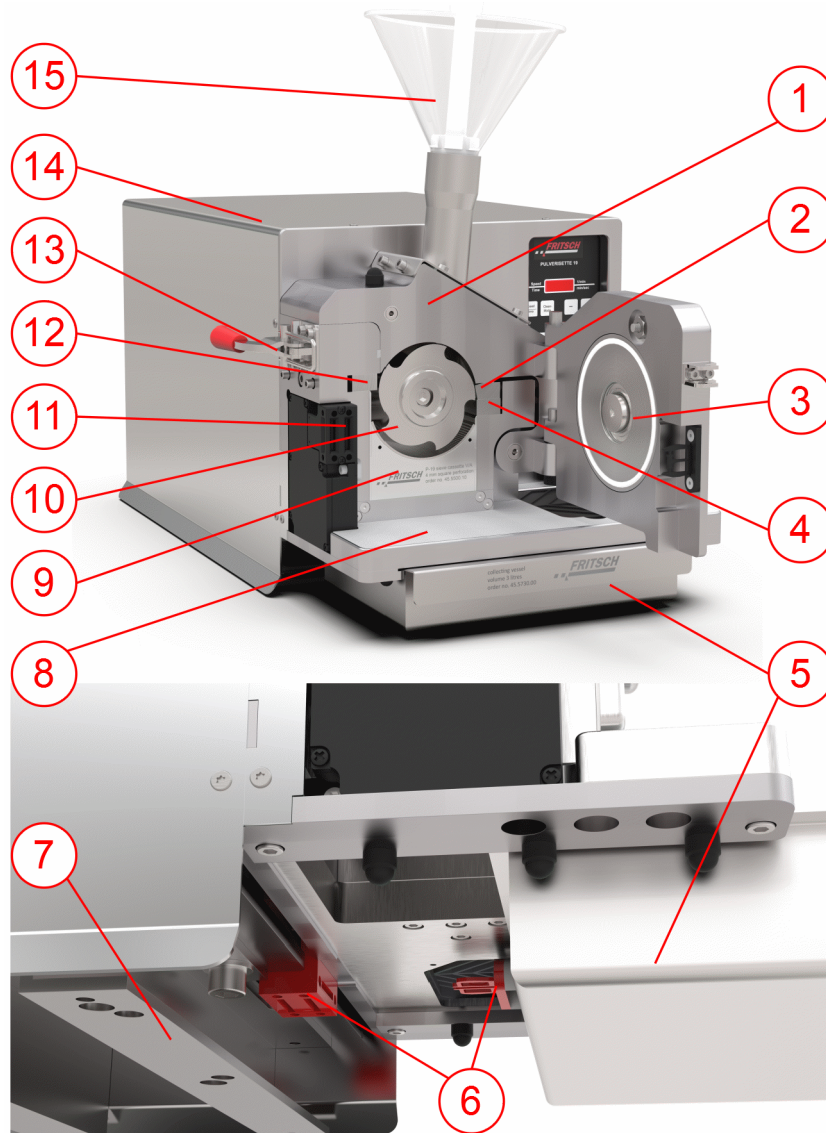

- 1 Upper part of housing
- 2 Fixed knife 1
- 3 Closing lid
- 4 Fixed knife 2

- 5 Collecting vessel
- 6 Safety switch / safety switch bracket
- 7 U-profile
- 8 Lower part of housing

Basic structure

- 9 Sieve cassette
- 10 Rotor
- 11 Lock
- 12 Fixed knife 2

- 13 Latch clamp
- 14 Motor cover
- 15 Standard funnel

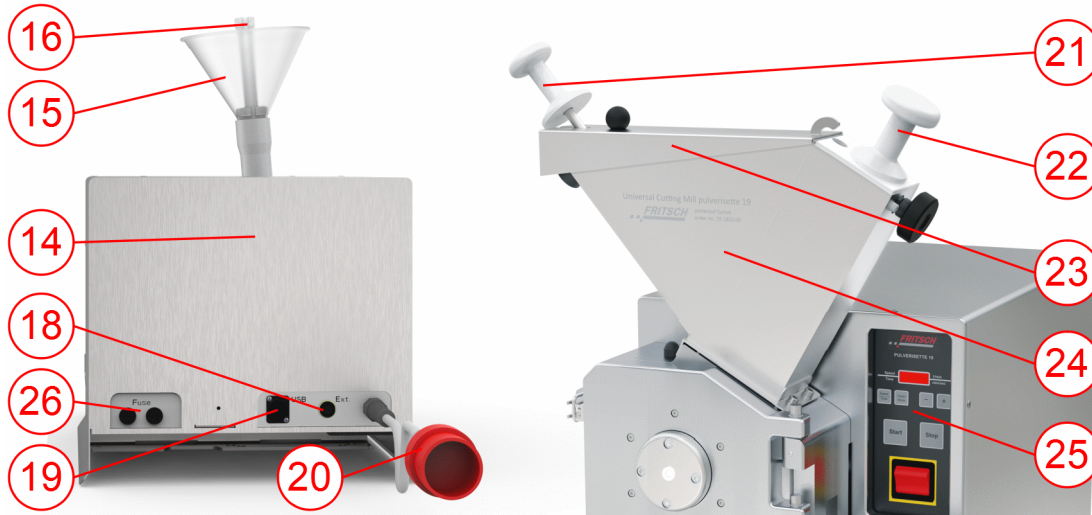

- 15 Standard funnel
- 14 Motor cover
- 16 Plunger, standard funnel
- 17 Ventilation grid
- 18 External 3-pole connection
- 19 USB interface
- 20 Mains plug

- 21 Sample pusher
- 22 Plunger (protected funnel)
- 23 Funnel lid
- 24 Protected funnel
- 25 Control panel
- 26 Fuse

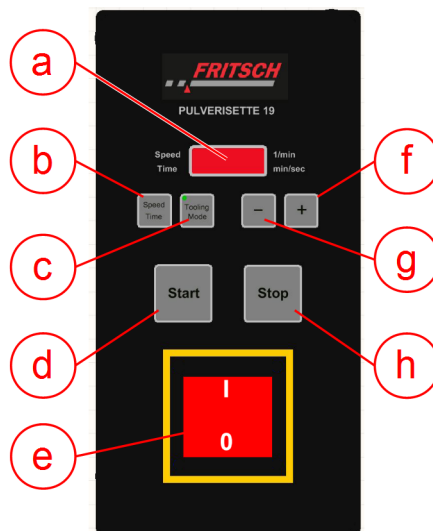

- a Display for speed and time
- b Toggle function for the display
- c Tooling Mode (P19 versions with speeds of 300 - 3000 rpm)
- d Start motor

- e Main switch with integrated overload protection
- f Increase speed / time
- g Decrease speed / time
- h Stop motor

2 Safety information and use

2.1 Requirements for the user

This operating manual is intended for persons assigned with operating and monitoring the Fritsch PULVERISETTE 19. The operating manual and especially its safety instructions are to be observed by all persons working on or with this device. In addition, the applicable rules and regulations for accident prevention at the installation site are to be observed. Always keep the operating manual at the installation site of the PULVERISETTE 19.

People with health problems or under the influence of medication, drugs, alcohol or exhaustion must not operate this device.

The PULVERISETTE 19 may only be operated by authorised persons and serviced or repaired by trained specialists. All commissioning, maintenance and repair work may only be carried out by technically qualified personnel. Qualified personnel are persons who, because of their education, experience and training as well as their knowledge of relevant standards, regulations, accident prevention guidelines and operating conditions, are authorised by those responsible for the safety of the machine to carry out the required work and are able to recognize and avoid possible hazards as defined for skilled workers in IEC 364.

In order to prevent hazards to users, follow the instructions in this manual.

Malfunctions that impair the safety of persons, the PULVERISETTE 19 or other material property must be rectified immediately. The following information serves both the personal safety of operating personnel as well as the safety of the products described and any devices connected to them: All maintenance and repair work may only be performed by technically qualified personnel.

This operating manual is not a complete technical description. Only the details required for operation and maintaining usability are described.

Fritsch has prepared and reviewed this operating manual with the greatest care. However, no guarantee is made for its completeness or accuracy.

Subject to technical modifications.

2.2 Scope of application



NOTICE!

This laboratory instrument is designed for an 8-hour shift operation at 30 % duty cycle and not for continuous operation.

The duty cycle is defined as the ratio of load duration to run time. The run time is defined as load duration plus pause time. According to DIN EN 60034-1 (VDE 0530, IEC34-1) a continuous operation already takes place after a standardised run time of 10 minutes. At 30 % duty cycle (DC = ratio of load duration to run time) a load duration of 3 minutes and a pause time of 7 minutes would be within standard.

If the standardised run time of 10 minutes is exceeded, then, by definition, there would be a continuous operation and disproportionate temperature increases may occur, possibly involving increased wear.

The Universal Cutting Mill can be used for the fast comminution of soft, medium-hard, brittle, tough and fibrous materials like:

Sheet rubber, plastics, refuse-derived fuel, dry meat, leather, wood, coal, malt, paper/cardboard, peat, animal feed, pasta, tablets, leaves, pellets, spices, fabric, straw, maize, bones, roots, tobacco...

2.2.1 Operating principle

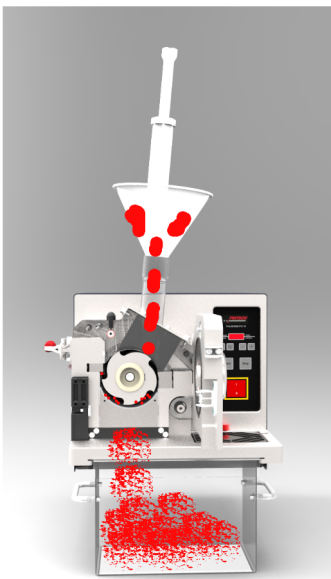

The material is fed through a funnel (example in image with standard funnel) into the cutting chamber. There, rotating knives (10) in combination with fixed knives (2,4,12) cut the material. The fine ground material falls through a sieve cassette (9) into the collecting vessel (5).

For fine comminution, the Fritsch high-performance cyclone separator (optional accessory 19.1900.00) can be used for the sample exhaustion.

2.3 Obligations of the operator

Before using the PULVERISETTE 19, this manual is to be carefully read and understood. The use of the PULVERISETTE 19 requires technical knowledge; only commercial use is permitted.

The operating personnel must be familiar with the content of the operating manual. For this reason, it is very important that these persons actually receive the present operating manual. Ensure that the operating manual is always near the device.

The PULVERISETTE 19 may exclusively be used within the scope of applications set down in this manual and within the framework of guidelines put forth in this manual. In case of non-compliance or improper use, the customer assumes full liability for the functional capability of the PULVERISETTE 19 and for any damage or injury arising from failure to fulfil this obligation.

By using the PULVERISETTE 19 the customer agrees with this and recognizes that defects, malfunctions or errors cannot be completely excluded. To prevent risk of damage to persons or property or of other direct or indirect damage, resulting from this or other causes, the customer must implement sufficient and comprehensive safety measures for working with the PULVERISETTE 19.

Neither compliance with this manual nor the conditions and methods used during installation, operation, use and maintenance of the PULVERISETTE 19 can be monitored by Fritsch GmbH. Improper execution of the installation can result in property damage and thus endanger persons. Therefore, we assume absolutely no responsibility or liability for loss, damage or costs that result from errors at installation, improper operation or improper use or improper maintenance or are in any way connected to these.

The applicable accident prevention guidelines must be complied with.

Generally applicable legal and other obligatory regulations regarding environmental protection must be observed.

2.4 Information on hazards and symbols used in this manual

Safety information

Safety information in this manual is designated by symbols. Safety information is introduced by keywords that express the extent of the hazard.



DANGER!

This symbol and keyword combination points out a directly hazardous situation that can result in death or serious injury if not avoided.

Safety information and use



WARNING!

This symbol and keyword combination points out a possibly hazardous situation that can result in death or serious injury if not avoided.



CAUTION!

This symbol and keyword combination points out a possibly hazardous situation that can result in slight or minor injury if not avoided.



NOTICE!

This symbol and keyword combination points out a possibly hazardous situation that can result in property damage if not avoided.

Special safety information

To call attention to specific hazards, the following symbols are used in the safety information:



DANGER!

This symbol and keyword combination points out a directly hazardous situation due to electrical current. Ignoring information with this designation will result in serious or fatal injury.



DANGER!

This symbol and keyword combination designates contents and instructions for proper use of the machine in explosive areas or with explosive substances. Ignoring information with this designation will result in serious or fatal injury.



DANGER!

This symbol and keyword combination designates contents and instructions for proper use of the machine with combustible substances. Ignoring information with this designation will result in serious or fatal injury.



WARNING!

This symbol and keyword combination points out a directly hazardous situation due to movable parts. Ignoring information with this designation can result in hand injuries.

Safety information and use



WARNING!

This symbol and keyword combination points out a directly hazardous situation due to hot surfaces. Ignoring information with this designation can result in serious burn injuries due to skin contact with hot surfaces.

Safety information in the procedure instructions

Safety information can refer to specific, individual procedure instructions. Such safety information is embedded in the procedure instructions so that the text can be read without interruption as the procedure is being carried out. The keywords described above are used.

Example:

1. ➤ Loosen screw.

2. ➤



CAUTION!

Risk of entrapment at the lid.

Close the lid carefully.

3. ➤ Tighten screw.

Tips and recommendations



This symbol emphasises useful tips and recommendations as well as information for efficient operation without malfunction.

2.5 Device safety information

Please observe!

- Only use original accessories and original spare parts. Failure to observe this instruction can compromise the safety of the machine.
- Accident-proof conduct is to be strictly followed during all work.
- Comply with all currently applicable national and international accident prevention guidelines.



CAUTION!

Wear hearing protection!

If a noise level of 85 dB(A) is reached or exceeded, ear protection should be worn to prevent hearing damage.

Safety information and use



WARNING!

The maximum accepted concentration (MAC) levels of the relevant safety guidelines must be observed; if necessary, ventilation must be provided or the machine must be operated under an extractor hood.



DANGER!

Explosion hazard!

- When Comminution oxidizable substances, e.g. metals or coal, there is a risk of spontaneous combustion (dust explosion) if the share of fine particles exceeds a certain percentage. When Comminution these kinds of substances, special safety measures must be taken and the work must be supervised from a specialist.
- The PULVERISETTE 19 is not explosion protected and is not designed to **[ERROR: Missing definition for variable "to_materialbearbeitung"!]** explosive materials.

- Do not remove the information signs.



NOTICE!

Immediately replace damaged or illegible information signs.

- Unauthorised alteration of the PULVERISETTE 19 will void Fritsch's declaration of conformity to European directives and void the guarantee.
- Only use the PULVERISETTE 19 when it is in proper working order, as intended and in a safety- and hazard-conscious manner adhering to the operating manual. In particular, immediately rectify any malfunctions that could pose a safety hazard.
- If, after reading the operating manual, there are still questions or problems, please do not hesitate to contact our specialised personnel.

2.6 Protective equipment

- Protective equipment must be used as intended and may not be disabled or removed.
- All protective equipment must be checked regularly for integrity and proper functioning.
- The Universal Cutting Mill is equipped with a safety lock (11) which also protects the operator. This locks the front closing lid (3) during operation.

- The safety switches (11, 6) prevent operation of the Universal Cutting Mill, if the cutting chamber is not closed or a collecting vessel (8) has not been inserted.
- **Do not operate the device without a funnel (15 or 24)!**
Funnels (15, 24) are mechanical safety devices that enable hazard-free filling.
- When changing the funnels (15, 24), disconnect the device from the mains and install the new funnel (15, 24) immediately! (↪ Chapter 4.6 'Selecting and converting the funnels' on page 22)

2.6.1 Opening the cutting mill without mains connection



DANGER!

The lock must only be released manually when the closing lid is closed.

The latch clamp of the door must be locked!



Only open the cutting mill in this way if there are problems with your mains supply or with the safety lock. Opening the mill during the grinding process could damage the device.



1. ➔ Insert the supplied triangular key into the bore hole under the safety lock (11) and turn it clockwise.
2. ➔ The closing lid (3) can be opened after opening the latch clamp (13).

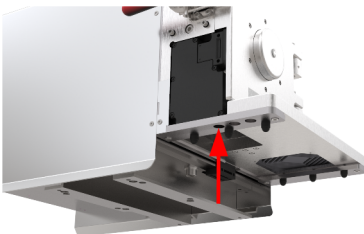

3. ➔ At this time, it is not possible to switch on the Universal Cutting Mill. To switch it on, the safety lock (11) must be activated by turning the triangular key to the left, the closing lid (3) must be closed and the latch clamp (13) in locked position.

Safety information and use

2.7 Hazardous points

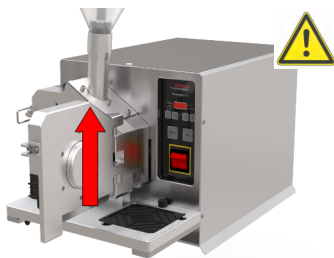

- The closing lid (3) can be lifted out of the hinges. When opening the upper part of the housing (1), it is possible to leave the closing lid (3) in the hinge. If this is the case, make sure that the closing lid (3) does not lift out of the hinge when opening the upper part of the housing (1).

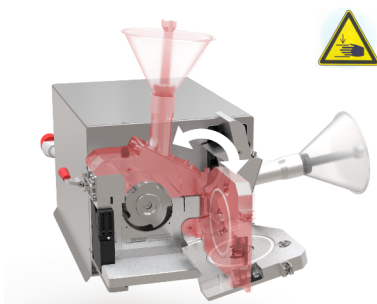

- When opening the upper part of the housing (1), there is an initial resistance.
- Make sure that the closing lid (3) is fully open!

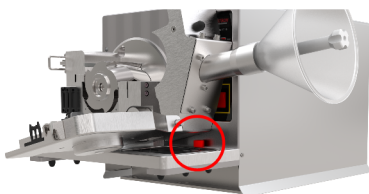

- When opening the upper part of the housing (1), slowly swivel it open until the upper part of the housing (1) is resting on the rubber buffer – do not let it fall into end position.
- There is a crushing hazard when closing the upper part of the housing (1). Close it slowly!

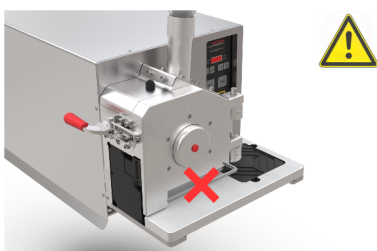

- After checking if the rotor (10) is turning freely (↪ Chapter 6.1.7 'Checking if the rotor is turning freely' on page 34), the required hexagon socket screw key has to be removed immediately.

2.8 Electrical safety

2.8.1 Protection against restart

If there is a power failure and subsequent return of the voltage during operation, the mill stops and the lock of the grinding chamber opens automatically.

2.8.2 Overload protection

- The main switch turns itself off automatically in case of an overload. The PULVERISETTE 19 must be switched on again by the user.

3 Technical data

3.1 Dimensions

without funnel: 440 mm x 790 mm x 350 mm
(width x depth x height)

3.2 Weight

300 - 3000 rpm:

- 60 kg without funnel, cutting tool set, sieve cassette, collecting vessel, and stand
- 68 kg incl. standard accessories

50 - 700 rpm:

- 79 kg without funnel, cutting tool set, sieve cassette, collecting vessel, and stand
- 87 kg incl. standard accessories

PULVERISETTE 19 *large*

300 - 3000 rpm:

- 63 kg without funnel, cutting tool set, sieve cassette, collecting vessel, and stand

50 - 700 rpm:

- 82 kg without funnel, cutting tool set, sieve cassette, collecting vessel, and stand

3.3 Speed

Serial number	Rotational speed
19.3000.00	50 - 700 rpm
19.3010.00	50 - 700 rpm
19.3020.00	300 - 3000 rpm
19.3030.00	300 - 3000 rpm
19.3040.00	50 - 700 rpm
19.3060.00	300 - 3000 rpm
19.3100.00	50 - 700 rpm
19.3110.00	50 - 700 rpm
19.3120.00	300 - 3000 rpm
19.3130.00	300 - 3000 rpm

Technical data

Serial number	Rotational speed
19.3140.00	50 - 700 rpm
19.3160.00	300 - 3000 rpm
19.4000.00	50 - 700 rpm
19.4020.00	300 - 3000 rpm
19.4040.00	50 - 700 rpm
19.4060.00	300 - 3000 rpm

3.4 Operating noise

The noise level is approx. 78 dB (A) when idle and 95 dB (A) when idle incl. cyclone separator. The value fluctuates strongly depending on the comminution material.

3.5 Voltage

19.3000.00	220-240 V / 1~	50 - 60 Hz
19.3010.00	100-120 V / 1~	50 - 60 Hz
19.3020.00	200-240 V / 1~	50 - 60 Hz
19.3030.00	100-120 V / 1~	50 - 60 Hz
19.3040.00	380-460 V / 3~	50 - 60 Hz
19.3060.00	380-460 V / 3~	50 - 60 Hz
19.3100.00	220-240 V / 1~	50 - 60 Hz
19.3110.00	100-120 V / 1~	50 - 60 Hz
19.3120.00	200-240 V / 1~	50 - 60 Hz
19.3130.00	100-120 V / 1~	50 - 60 Hz
19.3140.00	380-460 V / 3~	50 - 60 Hz
19.3160.00	380-460 V / 3~	50 - 60 Hz
19.4000.00	200-240 V / 1~	50 - 60 Hz
19.4020.00	200-240 V / 1~	50 - 60 Hz
19.4040.00	380-460 V / 3~	50 - 60 Hz
19.4060.00	380-460 V / 3~	50 - 60 Hz

3.6 Current consumption

- 19.3000.00 - 13 A
- 19.3010.00 - 16 A
- 19.3020.00 - 13 A
- 19.3030.00 - 16 A
- 19.3040.00 - 6 A
- 19.3060.00 - 13.5 A
- 19.3100.00 - 13 A
- 19.3110.00 - 16 A
- 19.3120.00 - 13 A
- 19.3130.00 - 16 A
- 19.3140.00 - 6 A
- 19.3160.00 - 13.5 A
- 19.4000.00 - 13 A
- 19.4020.00 - 13 A
- 19.4040.00 - 6 A
- 19.4060.00 - 13.5 A

Transient overvoltages in accordance with overvoltage category II are permitted.

3.7 Power consumption

- 19.3000.00 - 2350 W
- 19.3010.00 - 1725 W
- 19.3020.00 - 2350 W
- 19.3030.00 - 1725 W
- 19.3040.00 - 2800 W
- 19.3060.00 - 5000 W
- 19.3100.00 - 2350 W
- 19.3110.00 - 1725 W
- 19.3120.00 - 2350 W
- 19.3130.00 - 1725 W
- 19.3140.00 - 2800 W
- 19.3160.00 - 5000 W
- 19.4000.00 - 2350 W
- 19.4020.00 - 2350 W
- 19.4040.00 - 2800 W
- 19.4060.00 - 5000 W

3.8 Rotor torque

The torque depends on the device type.

Technical data

300 - 3000 rpm:

- Up to 30 Nm

50 - 700 rpm:

- Up to 67 Nm

3.9 Electrical fuses

The fuses are integrated into the mains switch and in the back side.

3.10 Material

Feed size

Depending on material and funnel (15,24), up to 70 x 80 mm. Harder material max. 10 mm.

Batch-wise sample feeding!

Throughput

Depending on material property and sieve used, up to 60 l/h.

Feed size PULVERISETTE 19 large

Depending on material, up to 120 x 85 mm. Harder material max. 20 mm.

Batch-wise sample feeding!

Throughput amount PULVERISETTE 19 large

Depending on material property and sieve used, up to 85 l/h.

3.11 Final fineness

Achievable average final fineness depending on sieve insert, 0.2 - 6 mm.

4 Installation

4.1 Transport

**CAUTION!**

When lifting off, at least 2 persons are required!

**DANGER!****Crushing hazard!**

Due to falling during transport.

Wear safety shoes!

- Transport on transport palette with a forklift or pallet truck.
- When lifting the device hold it underneath at the back and front.

4.2 Unpacking

- Pull out the nails that fasten the crate to the transport pallet.
- Lift the crate off the transport pallet.
- Compare the contents of the delivery with your order.

4.3 Setting up

- 4 screws connect the cutting mill to the transport pallet.
Remove the 4 screws.
- Lift the cutting mill off the transport pallet.

**CAUTION!**

When lifting off, at least 2 persons are required!

4.4 Ambient conditions



- The device may only be operated indoors.
- The surrounding air may not carry any electrically conductive dust.
- The room temperature should be between 5 and 40 °C.
- Altitudes up to 2000 m NN.

Installation

- Maximum relative humidity 80% for temperatures up to 31 °C, linearly decreasing down to 50% relative humidity at 40 °C.
- Degree of pollution 2 according to IEC 664.

4.5 Fastening the Universal Cutting Mill

Screw the cutting mill tightly to the frame provided (acc. to instructions) or to a stable mount (table...). The following must be observed in order to fasten the device:

- Two U-profiles (7) are mounted on the bottom of the device. Insert the 4 screws provided through the bore holes in the U-profiles (7) and screw tightly to the frame or table. Other screws with the same diameter can also be used.

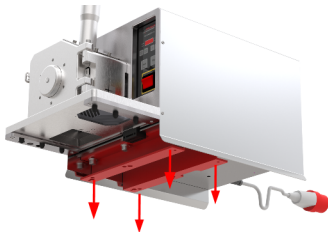

WARNING!

Ensure that the device is safely fastened. Sizeable lateral forces can occur!



NOTICE!

- Make sure that the cutting mill is easily accessible. On the right of the mill, there must be enough space to open the upper part of the housing together with the funnel.
- Make sure the ventilation grate on the back is not obstructed. **Risk of overheating!**

4.6 Selecting and converting the funnels



The PULVERISETTE 19 large is available only with the protected funnel (25.2850.00).

4.6.1 Selecting the funnel

The standard funnel (15) is used for long and bulk solids, for free-flowing material, but also for the comminution of long goods, like for example straw or wood. The protected funnel (24) is used for all other materials.

4.6.2 Converting from standard funnel to protected funnel

1. ➤ Close the cutting mill.
2. ➤ Switch main switch to 0.
3. ➤ Remove the mains plug (20).
4. ➤ Unscrew the four M6x12 cylinder head screws which fasten the standard funnel (15) to the upper part of the housing (1) using a hexagon socket screw key and lift off the standard funnel (15).



5. ➤ Insert the protected funnel (24) and fasten it with the four M6x12 cylinder head screws and the washers.
6. ➤ Connect the cutting mill again to the mains.
⇒ The device is ready for operation.

Installation

4.6.3 Converting from protected funnel to standard funnel

1. ➤ Close the cutting mill.
2. ➤ Close the funnel lid (23).
3. ➤ Remove the mains plug
4. ➤ Unscrew the four M6x12 cylinder head screw which fasten the protected funnel (24) to the upper part of the housing (1) using a hexagon socket screw key and lift off the protected funnel (24).



5. ➤ Insert the standard funnel (15) and fasten it with the four M6x12 cylinder head screws and the washers.
6. ➤ Connect the cutting mill again to the mains.
7. ➤ Switch on main switch.
⇒ The device is ready for operation.



4.7 Electrical connection

Before establishing the connection, compare the voltage and current values stated on the type plate with the values of the mains system to be used.

(see  Chapter 3 'Technical data' on page 17).

4.8 Set-up mode



NOTICE!

Changing the setting 'Machine speed' in setup mode can cause damage to the device. Never modify these settings without first consulting Fritsch Service.

To enter the setup mode, press and hold the 'Stop' button while you switch on the device. Once you are in setup mode, the following display is shown in which you can specify 3 settings:



- a - Time display in minutes or seconds
- b - Connection of external devices - vibration feeder LABORETTE 24 or cyclone separator

To use the cyclone separator, you need the adapter 19.3073.00.

- c - Machine speed

Modify this setting only upon consulting Fritsch Service.

Initial start-up

5 Initial start-up

5.1 Switching on

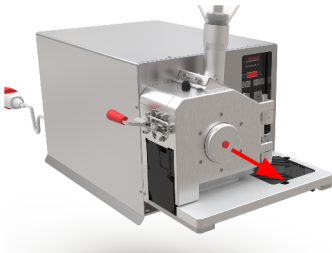

1. ➤ Connect the device to the mains with the mains plug (20).
2. ➤ Switch on the main switch on the front of the device.
3. ➤ Remove the cover cap of the central bore hole in the closing lid (3).



4. ➤ Insert the provided hexagon socket screw key through the central bore hole. Then turn the hexagon socket screw key to check if the rotor (10) is turning freely.



5. ➤ **Remove the hexagon socket screw key again!**
 - ⇒ If the rotor (10) is not turning freely, proceed as described in [Chapter 6.1.3 'Setting the gap width of the knives'](#) on page 30.



NOTICE!

This check must also be carried out every time the rotor, the fixed knives and the sieve cassette are changed!

6. ➤ Finally, insert the collecting vessel correctly.

5.2 Function check

Press the START button to switch on the device. This front closing lid (3) is now locked.

→ The cutting mill starts up.

**NOTICE!**

Switch the device off immediately if there is an audible metal contact noise. This can happen if the fixed knives are set incorrectly. An indication of this could be shiny areas on the rotor, which show where the fixed knives must be readjusted. (See  *Chapter 6.1.2 'Inserting / changing the fixed knives' on page 29*).

5.3 Switching off

Press the STOP button to switch off the device. After waiting a few seconds the closing lid (3) can be opened.

Switch off the main switch if the cutting mill is to be idle for a longer period of time (e.g. overnight).

**CAUTION!**

Never unlock the latch clamp during operation!
Risk of permanent damage to the rotor.

6 Using the device



WARNING!

If the grinding elements used are not original accessories, we provide no guarantee and exclude all liability for damage to the device.

6.1 Preparing a comminution

6.1.1 Opening the cutting mill



1. ➤ Switch on the main switch on the front.
2. ➤ Unlock the latch clamp (13).
3. ➤ Open the closing lid (3). It is possible to lift the closing lid (3) out of the hinge after opening. This is required for easier cleaning, for example.

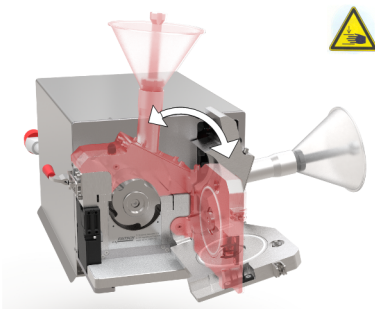

4. ➤ Make sure that the closing lid (3) is fully open!
Slowly swivel open the upper part of the housing (1) until it rests on the rubber buffer.

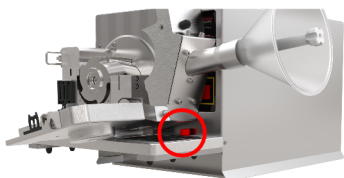

6.1.2 Inserting / changing the fixed knives

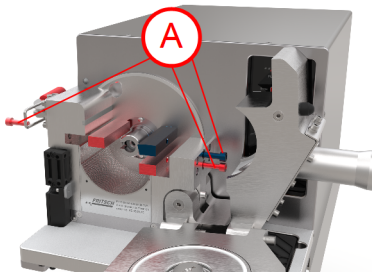

1. ➔ Open the cutting mill (see [Chapter 6.1.1 'Opening the cutting mill'](#) on page 28)
2. ➔ When inserting or changing the fixed knives (2, 4, 12) the rotor (10) and the sieve cassette (9) must be removed (see [Chapter 6.1.4 'Inserting / changing a rotor'](#) on page 31 and [Chapter 6.1.5 'Inserting / changing a sieve cassette'](#) on page 33).
3. ➔ Loosen the retaining screws (A) to change or remove the fixed knives (2, 4, 12).
4. ➔ When inserting, fasten the fixed knives (2, 4, 12) with the retaining screw (A).
5. ➔ After mounting the rotor (10) (see [Chapter 6.1.4 'Inserting / changing a rotor'](#) on page 31) set the gap width of the knives (see [Chapter 6.1.3 'Setting the gap width of the knives'](#) on page 30).

6.1.2.1 Installation position of the fixed knives

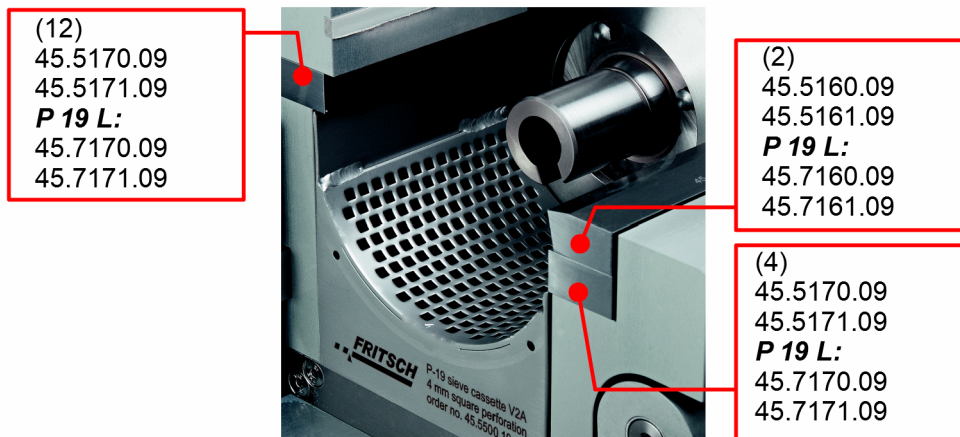

- (12) Fixed knife 2
- (2) Fixed knife 1
- (4) Fixed knife 2

Using the device

6.1.2.2 Installation position of the fixed knives with tungsten carbide cutting edge

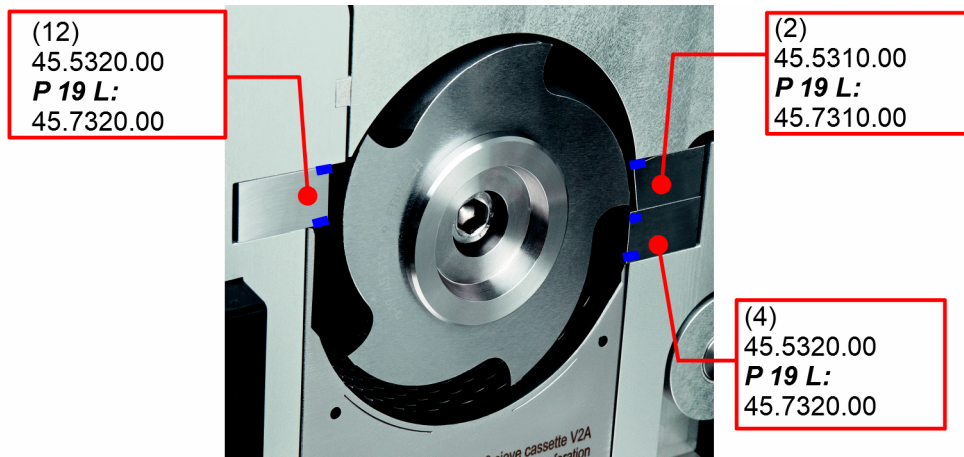

- (12) Fixed knife 2
- (2) Fixed knife 1
- (4) Fixed knife 2



NOTICE!

Note the position of the Tungsten Carbide hard metal strips. These are marked BLUE in the image above.

6.1.3 Setting the gap width of the knives

The knife gap is set at the factory to approx. 0.2 mm.

1. ➤ Open the cutting mill (see ↪ Chapter 6.1.1 'Opening the cutting mill' on page 28).
2. ➤ Loosen the middle retaining screws (A) on all 3 fixed knives (2, 4, 12) and unscrew them slightly.
3. ➤ Turn the rotor (10) so that the rotor knife and the fixed knife (2, 4, 12) are exactly opposite each other.

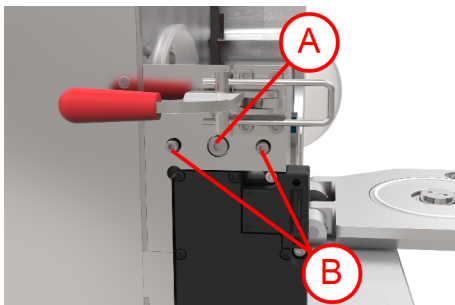

- A Retaining screw to fasten and loosen the fixed knife when setting the gap width of the knives.
- B Threaded pins to set the cutting gap.

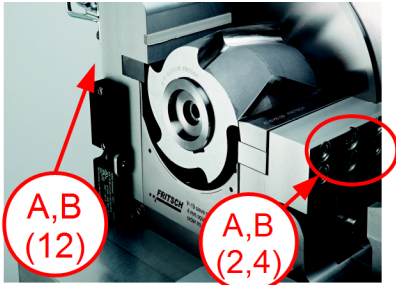

A, B (12) Retaining screw (A) and threaded pins (B) for fixed knife (12)

A, B (2, 4) Retaining screws (A) and threaded pins (B) for fixed knife (2, 4)

4. ➤ Screw in the right and left threaded pins (B) beside the retaining screw (A) equally until the fixed knives (2, 4, 12) come up against the rotor knives.
5. ➤ Then turn the threaded pins (B) evenly back by $\frac{1}{4}$ of a turn and retighten the retaining screw (A).
6. ➤ Set all 3 fixed knives (2, 4, 12) in this way.

A knife gap of approx. 0.2 mm is then set using this method. This can be checked using a feeler gauge. (0.2 mm, approx. 2 sheets of printing paper, DIN A4 80 g)



NOTICE!

The fixed knives must run parallel to the rotor knives so that the cutting load is distributed evenly across the whole length.

7. ➤ Insert the sieve cassette (9) (see [Chapter 6.1.5 'Inserting / changing a sieve cassette'](#) on page 33).
8. ➤ Close the cutting mill (see [Chapter 6.1.6 'Closing the cutting mill'](#) on page 34).



NOTICE!

Check if the rotor is turning freely (see [Chapter 6.1.7 'Checking if the rotor is turning freely'](#) on page 34).

If this is not the case, proceed as described in [Chapter 6.1.3 'Setting the gap width of the knives'](#) on page 30.

This check must also be carried out every time the rotor and the knife are changed!

6.1.4 Inserting / changing a rotor



CAUTION!

Risk of injury!

Beware of the sharp edges of the rotor!

Wear safety gloves when changing the rotor!

Using the device



Tooling Mode

Devices with a rotational speed of 300 - 3000 rpm, feature a 'Tooling Mode'. In this mode, the rotor can be blocked with opened door. This allows for a better replacement of the rotor.

The rotor must not be turned when Tooling Mode is activated!

Tooling Mode can be switched on only when the grinding chamber is open and switches itself off automatically again after 10 seconds or when the grinding chamber is closed.

An active Tooling Mode can be recognised by the lit LED direct at the button or the word 'tool' shown in the display.

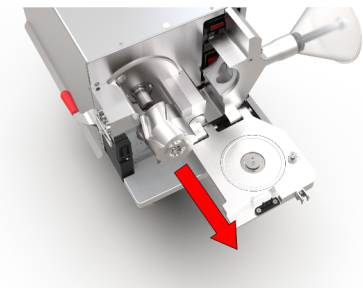

1. ➤ Open the cutting mill (see [Chapter 6.1.1 'Opening the cutting mill'](#) on page 28).
2. ➤ Pull the rotor (10) forwards, wearing **safety gloves**. If the rotor (10) jams somewhat, lever it out carefully.

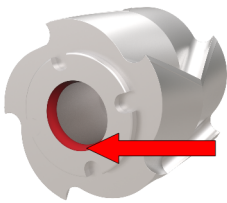

3. ➤ Clean the cone-shaped rotor holders (10).

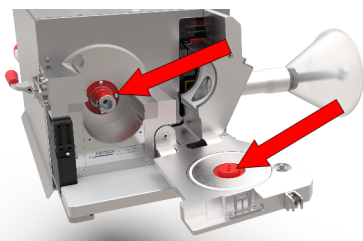

4. ➤ Clean both cone-shaped holders (cones) in the closing lid (3) and on the holder.

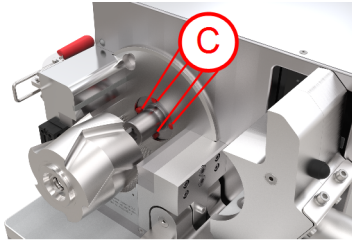

5. ➔ Push the rotor (10) onto the rotor holder. Turn it clockwise until it engages in the 4 actuating pins (C) on the back. (Tooling Mode needs to be activated in devices with 300 - 3000 rpm)
6. ➔ Close the cutting mill (see ↪ Chapter 6.1.6 'Closing the cutting mill' on page 34).



NOTICE!

Check if the rotor is turning freely (see ↪ Chapter 6.1.7 'Checking if the rotor is turning freely' on page 34).

If this is not the case, proceed as described in ↪ Chapter 6.1.3 'Setting the gap width of the knives' on page 30.

This check must also be carried out every time the rotor and the knife are changed!

6.1.5 Inserting / changing a sieve cassette

1. ➔ Open the cutting mill (see ↪ Chapter 6.1.1 'Opening the cutting mill' on page 28).
2. ➔ Pull out the sieve cassette (9) to the front. The rotor (10) must not be removed.

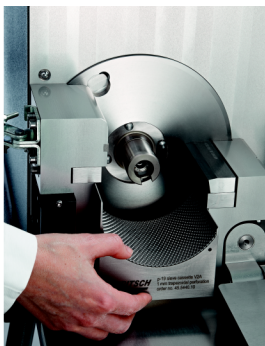

Use the pulling tool (X) 45.5550.10 to pull out the sieve cassette (9): Insert the pulling tool into the two holes of the sieve cassette (9) past the bends of the pulling tool. While inserting the pulling tool, move it slightly up and down.

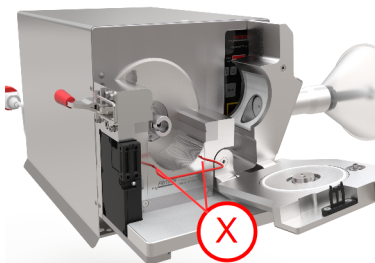

3. ➔ If the sieve cassette (9) is jammed, remove the comminution material under the fixed knife (12) on the left side of the housing with a screwdriver.
4. ➔ Before pushing in the sieve cassette (9) clean the cutting chamber thoroughly, so that everything can be closed tightly again.
5. ➔ Close the cutting mill (see ↪ Chapter 6.1.6 'Closing the cutting mill' on page 34).

Using the device

6.1.5.1 Selecting the sieve cassette

Coarse material should be roughly crushed with the coarse 2-4 mm sieve and comminuted in the second work step to the desired final fineness. The sample exhaust system with cyclone separator can be used for fine comminution < 2 mm.

6.1.6 Closing the cutting mill

1. ➤ Before closing the cutting mill, clean the cutting chamber, the contact surfaces of the housing and, in particular, the locking surfaces of the lock.
2. ➤ Slowly swivel shut the upper part of the housing (1) until the funnel opening points upwards.
3. ➤ Close the closing lid (3).
4. ➤ Lock the latch clamp (13).

6.1.7 Checking if the rotor is turning freely

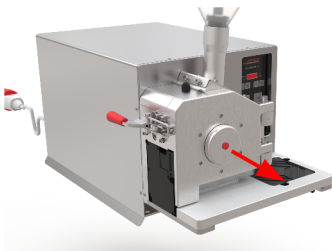

- To check if the rotor is turning freely, the closing lid has to be closed.
- Switch off the device at the main switch.
- Remove the cover cap of the central bore hole in the closing lid.



- Guide the hexagon socket screw key provided through the central bore hole in the closing lid.
- Now turn the hexagon socket screw key to check if the rotor is turning freely.

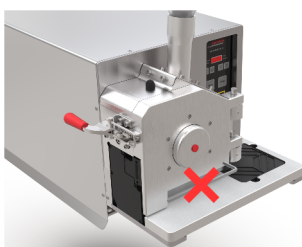

- Remove the hexagon socket screw key again **immediately!**
- If the rotor is not turning freely, proceed as described in [Chapter 6.1.3 'Setting the gap width of the knives'](#) on page 30.



NOTICE!

Perform this test each time the rotor or fixed knife is changed, and after a gap adjustment!

6.2 Comminution procedure with standard funnel



CAUTION!

Wear safety goggles for comminution using the standard funnel!

In the case of free-flowing material, particles could be ejected from the funnel.

1. ➤ Switch the device on at the main switch.
2. ➤ Close the cutting mill (see ↪ *Chapter 6.1.6 'Closing the cutting mill' on page 34*).
3. ➤ Push in the collecting vessel (5).
4. ➤ Pull the plunger out fully.
5. ➤ Switch on the device → press the Start button (see ↪ *Chapter 5.1 'Switching on' on page 26*).
6. ➤ Add some comminution material.

⇒ An operating noise becomes audible.

The quantity of comminution material varies depending on the particle feed size and the grindability of the comminution material. It is best to start with small quantities and increase them depending on the success of the comminution.

7. ➤ If necessary, press the comminution material into the cutting chamber with the plunger.
8. ➤ When the operating noise becomes quieter, the comminution procedure is complete.
 - ⇒ More comminution material can be added.

6.2.1 Using the plunger



The plunger has 2 different sides for feeding the sample material in the funnel to the grinding chamber. On the one hand, the smooth, round side is suitable for finer material. On the other hand, the cross-shaped, thinner side is suitable for long, fibrous material, like straw.

6.3 Comminution procedure with the protected funnel

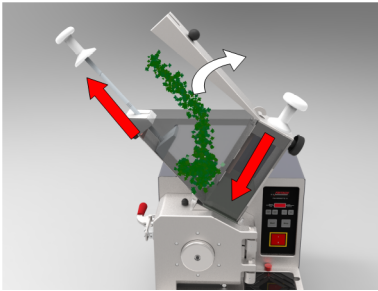

1. ➤ Switch the device on at the main switch.
2. ➤ Close the cutting mill (see ↪ Chapter 6.1.6 'Closing the cutting mill' on page 34).
3. ➤ Push in the collecting vessel (5).
4. ➤ Pull the sample pusher (21) out fully.
5. ➤ Move the plunger (22) into the lower position.
6. ➤ Flip open the funnel lid (23), add some comminution material and close the lid again.

The quantity of comminution material varies depending on the particle feed size and the grindability of the comminution material. It is best to start with small quantities and increase them depending on the success of the comminution.



7. ➤ Switch on the device → press the Start button (↪ Chapter 5.1 'Switching on' on page 26).
8. ➤ Move the sample pusher (21) down towards the plunger (22) until the comminution material is in front of the plunger (22).
9. ➤ Pull the plunger (22) upwards and move the sample pusher (21) fully downwards until the comminution material falls into the cutting chamber.
 - ⇒ A slight operating noise becomes audible.



10. ➤ Leave the sample pusher (21) down and move the plunger (22) downwards.
 - ⇒ The operating noise becomes louder.
11. ➤ Make pumping movements with the plunger (22). These pumping movements draw in and press out air through the blower filter above the collecting vessel. This air feeds the comminution material through the sieve or lifts it off the sieve and back into the process.
12. ➤ When the operating noise becomes quieter, the cutting procedure is complete.
 - ⇒ More comminution material can be added.

6.4 Overload of the cutting mill

When filling and making downward movements with the plunger (22) the operating noise must be observed. The sound level is nearly identical to the load on the machine. You can clearly hear from the pitch when the mill reduces speed due to overload.

Pulling the plunger (22) out on time reduces the load on the mill and protects the rotor (10), the fixed knives (2, 4, 12) and the sieve cassette (9).

**NOTICE!**

If the cutting mill is overloaded, the fuse in the main switch switches the device off.

Then proceed as follows:

- 1.** → Allow the device to cool down.
- 2.** → Switch main switch back on after brief cooling phase.

6.5 Sample exhaust system with cyclone separator



For sample exhaustion with the high-performance cyclone separator in combination with the PULVERISETTE 19 large, please contact Fritsch or your sales partner.

The small volume cyclone separator is not recommended in combination with the PULVERISETTE 19 large.

Using the device

6.5.1 High-performance cyclone separator



A dust exhaust system (43.9070.00) is needed to use the high-performance cyclone separator.

- 27 Adapter for exhaust system
- 28 Connection hose
- 29 Rubber sleeve
- 30 Cyclone separator
- 31 Dust exhaust connection
- 32 Sample bottle
- 33 Adapter for sample bottle
- 34 Swivelling stainless steel stand



CAUTION!

Hearing damage!

Wear hearing protection during sample extraction with the cyclone separator!

(Optional accessory order number: 19.1900.00)

The sample exhaust system with high-performance cyclone separator can be used for fine comminution.

1. ➔ Push the adapter for the exhaust system (27) into the lower part of the housing (8).



When using the cyclone separator, the filter above the collecting vessel is automatically covered by the adapter.

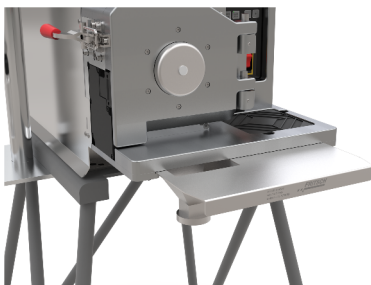

2. ➔ Attach one end of the connection hose (28) with the rubber sleeve (29) to the adapter for exhaust (27) and the other end to the cyclone separator (35).
3. ➔ Close the cutting mill with mounted standard funnel (15) (see ↗ Chapter 6.1.6 'Closing the cutting mill' on page 34).
4. ➔ Screw the sample bottle (31) onto the adapter (33) on the cyclone separator (30); make sure the connection hose is firmly connected and switch on the exhaust system.
5. ➔ Switch on the cutting mill (see ↗ Chapter 5.1 'Switching on' on page 26).
6. ➔ Add a little comminution material by hand and observe the operating noises. If the motor speed decreases audibly, reduce the supply of comminution material. A fast vortex of comminution material must form in the collection bottle.

The quantity of comminution material is based on the particle feed size and the grindability of the material. It is best to start with small quantities and increase them depending on the success of the comminution.

**NOTICE!**

When the sample bottle (32) is 2/3 full, stop the comminution. To do this, switch off the cutting mill (see [Chapter 5.3 'Switching off' on page 27](#)) and the sample exhaust system. Then empty the sample bottle (32).

If comminution has not stopped when the bottle is 2/3 full, the effectiveness of the cyclone separator will decline.

If the vortex of comminution material in the collection bottle slows down, this means that the air throughput or air flow rate has decreased:

- grinding chamber is too full
- the sieve has to be cleaned and / or
- the filter of the exhaust system has to be cleaned.

**NOTICE!**

The fine material (fine dust) of the sample collects in the filter of the sample exhaust system. Clean the filter from time to time by vacuuming or blowing out.

The sample exhaust system is recommended especially in combination with the standard funnel (15) for bulk and long solids.

6.5.2 Small volume Cyclone separator



The small volume Cyclone separator can be used for the sample exhaustion of small sample quantities!



When using the small volume Cyclone separator in combination with the P-19, the cyclone can only be used actively with an extraction system.

Using the device



- | | |
|---|--|
| 1 Connection vacuum cleaner | 6 Coupling for spiral hose (45.5986.15) |
| 2 Small volume Cyclone separator | 7 Adapter for sample extraction (19.1800.00) |
| 3 Stand | 8 Rubber collar 40 mm (45.5985.15) |
| 4 Sample glass | 9 Hose sample extraction (45.5980.00) |
| 5 Particle inlet pipe for connecting with the Adapter for sample extraction | |

1. ➤ Connect all parts as shown in the previous image.
2. ➤ Switch on the exhaust system.
3. ➤ Switch on the PULVERISETTE 19.
4. ➤ Add the sample in small amounts into the funnel.
5. ➤ As soon as the collecting vessel underneath the small volume Cyclone separator is 3/4 full, stop adding the sample and empty or replace the collecting vessel!

7 Cleaning

**NOTICE!**

Depending on the moisture content of the material to be comminuted, the mill must be freed from residues and cleaned after each grinding operation.

7.1 Housing

The cutting mill can be wiped down with a damp cloth when it is switched off. Disconnect the mains plug (20) from the electricity.

**DANGER!**

Do not allow any liquids to flow into the device.

7.2 Cutting chamber

Clean the cutting chamber with a vacuum cleaner and brush, and with compressed air, if necessary.

**CAUTION!**

Beware of dust exposure caused by cleaning with compressed air!

**CAUTION!****Klemmgefahr!**

If the 'Tooling-Mode' is activated (only for units with 300 - 3000 rpm), the motor shaft is blocked!

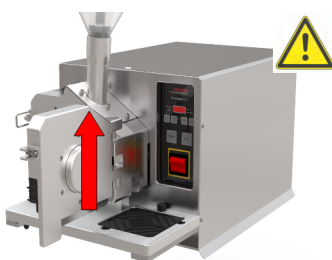

1. → Unlock the latch clamp (13).
2. → Open the closing lid (3) fully. This can be lifted out of the hinge at an opening angle of 90° for cleaning.
3. → Activate 'Tool Mode'. (Only with devices with 300 - 3000 rpm)

Cleaning

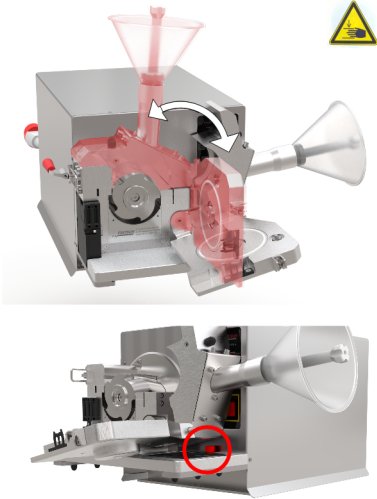

4. ➤ Slowly swivel open the upper part of the housing (1) with the closing lid (3) fully open until it is resting on the rubber buffer.
5. ➤ Clean the cutting chamber.

7.3 Funnel

Clean the funnels (15, 24) with a dust exhaust system and brush and also with compressed air, if necessary.

7.3.1 Standard funnel (15)

1. ➤ With the cutting chamber open, vacuum out the funnel from below
2. ➤ Clean the funnel from above.

7.3.2 Protected funnel (24)



1. ➤ Switch the device off at the main switch.
2. ➤ Pull the sample pusher (21) out of the protected funnel (24) until it stops. The sample pusher has 2 notches. The sample pusher can be set into these two positions.
3. ➤ Open the funnel lid (23).
4. ➤ Clean the protected funnel (24) from above.
5. ➤ Close the funnel lid (23).



6. ➤ Pull the plunger (22) out of the protected funnel (24) until it stops and fasten it with knurled screw (B).
7. ➤ Open the cutting chamber as described above.
8. ➤ Clean the protected funnel (24) from below.

If necessary!

It is also possible to remove the plunger (22) and the sample pusher (21) for cleaning. Switch off the main switch and disconnect the mains plug (20).

7.3.2.1 Removing sample pusher (21)

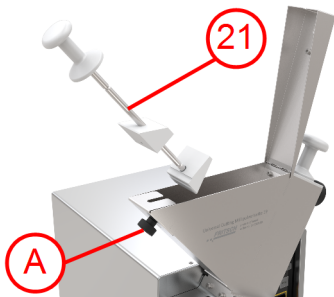

1. ➤ Open the funnel lid (23).
2. ➤ Unscrew the knurled screw (A).
3. ➤ The sample pusher (21) can be taken out.
4. ➤ Install in reverse order.

7.3.2.2 Removing the plunger (22)

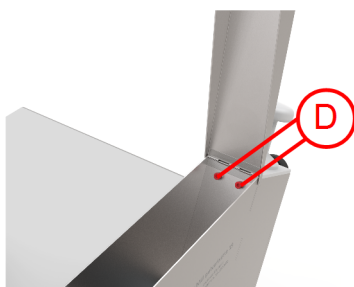

1. ➤ Open the funnel lid (23).
2. ➤ Unscrew the Torx screws (D) with a screwdriver.
3. ➤ Close the funnel lid (23).

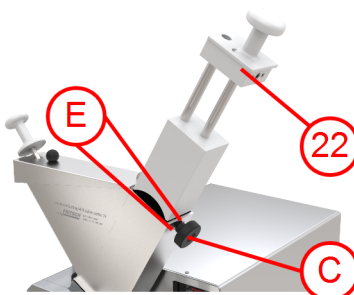

4. ➤ Unscrew the Torx screws (E) with a screwdriver.
5. ➤ Unscrew the knurled screw (C).
6. ➤ The plunger (22) can be taken out.
7. ➤ Install in reverse order.

Cleaning

7.4 Collecting vessel

Pull out the collecting vessel (5) and clean it. It can be vacuumed or wiped down with a damp cloth.



NOTICE!



Close the cutting mill after cleaning and check for proper functioning. See [Chapter 5 'Initial start-up'](#) on page 26.



NOTICE!



Make sure that the parts sit firmly when assembling.

7.5 Cleaning the filter foam mat

1.  Vacuum the filter foam mat with the vacuum cleaner.
2.  Subsequently wash it out with water. If necessary, you could use a tenside for cleaning.
3.  Allow the foam mat to air-dry!

7.6 Cleaning the labyrinth seal

Depending on the material to be comminuted and the duration of the comminution, the labyrinth seal must be cleaned regularly. To do this, proceed as follows:

1.  Open the grinding chamber.
2.  Remove the rotor.

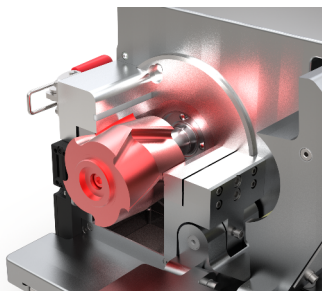

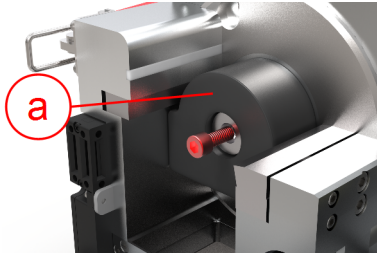

3. → Position the anti-rotation device (a) on the tool holder. If necessary, turn the tool holder so that the bolts of the anti-rotation device do not rest on the bolts of the tool holder.

4. → Loosen the hexagon socket screw in the tool holder.

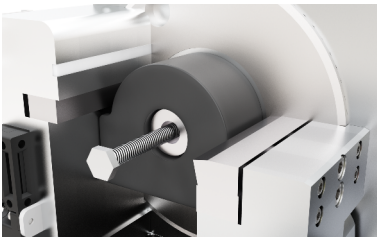

5. → Screw the hexagonal screw M10x130 into the tool holder. The narrow tip of the screw presses on the motor shaft inside the tool holder, pulling off the labyrinth seal.

6. → Disassemble the hexagon head screw M10x130 and remove the anti-rotation device.

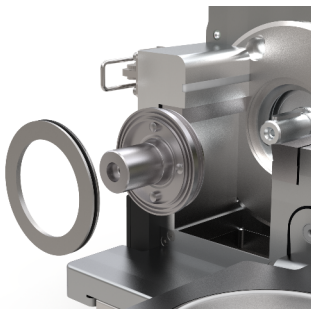

7. → Clean the labyrinth seal and the seal of the cover plate.

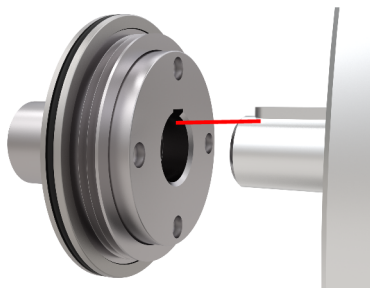

8. → To mount the tool holder with labyrinth seal, position the cover plate on the labyrinth seal and place the tool holder with seal on the motor shaft.



Pay attention to the cut-out on the tool holder so that it can be pushed onto the motor shaft.

Cleaning

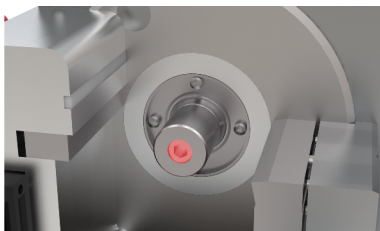
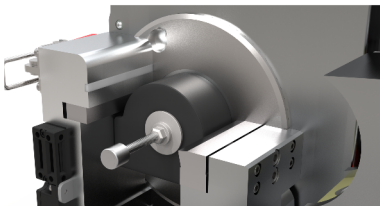
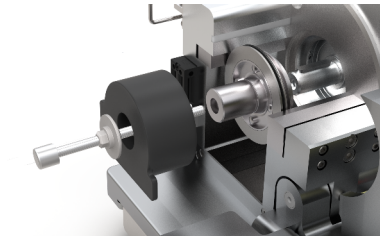

9. ▶ Take the anti-twist device and the M8x130 screw with the washer and mount it as shown in the picture.

10. ▶ When the labyrinth seal is completely pressed in, dismantle the M8x130 screw with the washer and remove the anti-rotation device.

11. ▶ Finally, screw the hexagon socket screw back into the tool holder.

7.7 Cleaning the labyrinth seal in the closing lid



In the 19.31X0.00, the labyrinth seal is not installed in the closing lid.

Depending on the material to be comminuted and the duration of the comminution, the labyrinth seal in the closing lid must be cleaned regularly. To do this, proceed as follows:

- 1.** ▶ Open the closing lid.
- 2.** ▶ Hold your left hand against the inside of the closing lid to prevent the labyrinth seal from falling down!
- 3.** ▶ To push out the labyrinth seal, use, for example, the hexagon socket screw key with which you check that the rotor is turning freely. Use it to press through the bore hole in the closing lid.

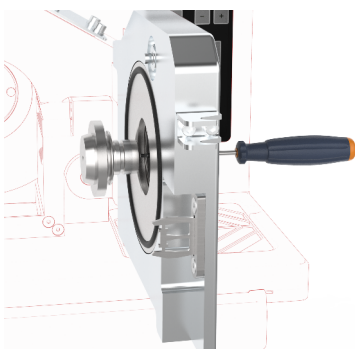

If you cannot remove the labyrinth seal just by pressing, close the closing lid with the sieve cassette inserted, but without the rotor. Take the hexagon socket screw key as described in the previous step and knock against it lightly with a hammer. The labyrinth seal should fall inwards onto the sieve cassette.

4. → When the labyrinth seal has fallen out, clean it and press it back in again with your hand.



Grease the labyrinth seal at regular intervals to ensure that it can be easily mounted and removed.

8 Maintenance



DANGER!

Mains voltage

- Before beginning with maintenance work, unplug the mains plug and protect the device against being unintentionally switched back on again!
- Indicate maintenance work with warning signs.
- Maintenance work may only be performed by specialised personnel.
- Put safety equipment back into operation after maintenance or repair work



We recommend keeping a safety logbook ↪ Chapter 13 'Safety logbook' on page 58, where all work (maintenance, repairs.....) performed on the device is entered.



The most important element of maintenance is regular cleaning!



- 26 Exhaust filter
- H Filter holder
- F Filter foam mat



Function / Functional part	Task	Test	Maintenance interval
Exhaust filter (26)	Filtering exhaust air	Clean exhaust filter (26). To do this, lever out the filter holder (H) with a screwdriver or similar. Beat the filter foam mat (F). Clean using compressed air or vacuum cleaner. Replace the filter foam mat (F) if it is very heavily soiled. Item number: 90.0740.16 filter foam mat.	Before every comminution
Safety lock (11)	Locking the closing lid (3)	Is the closing lid (3) locked shut when the main switch is deactivated? If NOT → safety lock (11) defective. Disconnect the device from the mains immediately. Replace the safety lock (11).	Before each use
Safety switch (6)	Protecting the lower opening of the cutting chamber	Is the cutting mill running without the collecting vessel (5) or the adapter for exhaust system (27)? If YES → safety switch (6) defective. Disconnect the device from the mains immediately. Replace the safety switch (6).	Before each use
Rotor (10)	Comminuting material	Is the rotor (10) sharp? If NO → sharpen	Before each use
Fixed knives (2, 4, 12)	Comminuting material	Are the fixed knives (2, 4, 12) sharp? Check visually! Maintenance: Resharpener	Before each use
Cutting gap	Cutting procedure	Measure gap width. For setting see ↪ Chapter 6.1.3 'Setting the gap width of the knives' on page 30.	Whenever rotor and fixed knives are changed
Cones	Centring rotor (10)	Check cones for cleanliness and grooves. See ↪ Chapter 6.1.4 'Inserting / changing a rotor' on page 31.	After each rotor change
Filter, sieve and sample exhaust system	Filtering exhaust air	Vortex of comminution material in the collection bottle slows down! For cleaning see ↪ Chapter 7 'Cleaning' on page 41!	Before each use

9 Repairs



DANGER!

Mains voltage!

- Before beginning with repair work, unplug the mains plug and protect the device against being unintentionally switched back on.
- Indicate repair work with warning signs.
- Repair work may only be performed by specialised personnel.
- Put safety equipment back into operation after maintenance work.

9.1 Checklist for troubleshooting

Fault description	Cause	Remedy
START button has been pressed but mill does not start up	Closing lid (3) not closed properly	Clean contact surface, close closing lid (3)
	Collecting vessel (5) or adapter for exhaust system (27) not inserted properly	Insert collecting vessel (5) or adapter for exhaust system (27) properly → until safety switch (11) engages.
	Coarse samples were added to the machine first and are blocking rotor start-up.	Open grinding chamber and remove sample material. → Switch on device before adding sample.
Mill stops running	Fuse in the main switch has triggered	Let the mill cool down and switch back on at the main switch (see Chapter 6.4 'Overload of the cutting mill' on page 36)
Comminution material is escaping	Material is extremely fine	Insert sample exhaust system (see Chapter 6.5 'Sample exhaust system with cyclone separator' on page 37)
Runs unevenly with strong vibrations	Rotor imbalance	Cones soiled (see Chapter 6.1.4 'Inserting / changing a rotor' on page 31)
	Bearing in closing lid (3) defective	Replace bearing
	Pieces broken off rotor (10)	Replace rotor (10) (Chapter 6.1.4 'Inserting / changing a rotor' on page 31)
	Rotor and fixed knives are touching each other (audible metal contact noise)	Switch device off immediately, disconnect from mains, check gap widths and correct. Check rotor and fixed knives for damage. (See Chapter 6.1.2 'Inserting / changing the fixed knives' on page 29)

9.2 Error messages



In case of several errors, these will be displayed in 3-second intervals!

No.	Fault description	Cause	Remedy
Er01	Collecting vessel not recognised!	Not inserted or inserted incorrectly.	Insert the collecting vessel correctly.
Er02	Collecting vessel safety circuit - channel discrepancy	A safety channel is not properly recognised.	Clean the safety switch and the actuator at the collecting vessel (if required with compressed air). If the error persists, contact Fritsch Service.
Er03	Short-circuit of an operating button		Contact Fritsch Service!
Er04	Motor temperature too high	The rotor is braked or the grinding chamber is too heavily soiled.	Clean the grinding chamber and the labyrinth seals (see Chapter 7.6 'Cleaning the labyrinth seal' on page 44 and Chapter 7.7 'Cleaning the labyrinth seal in the closing lid' on page 46). Check that the rotor moves freely. If necessary, add grinding stock more slowly and evenly.
Er05	Grinding chamber door not closed	Door not closed properly, surfaces of the grinding chamber door contaminated, or locks defective.	Close the grinding chamber door before starting. If the error exists despite the grinding chamber door being closed, clean the door switch (if necessary with compressed air). If the error persists, contact Fritsch Service.
Er06	Door contact safety circuit - channel discrepancy		Clean the safety switch and the actuator at the door (if required with compressed air). If the error persists, please contact Fritsch Service.
Er07	Door lock cannot be fully closed	Safety switch or grinding chamber door soiled.	Check the safety switch at the door for soiling. Clean the safety switch (if required with compressed air). If the error persists, please contact Fritsch Service.
Er08	Door lock cannot be fully opened.	Safety switch soiled	Check the safety switch at the door for soiling. Clean the safety switch (if required with compressed air). If the error persists, please contact Fritsch Service.
Er09	Door lock safety circuit - channel discrepancy		Check the safety switch at the door for soiling. Clean the safety switch (if required with compressed air). If the error persists, please contact Fritsch Service.
Er10	Motor initiator signals no speed during operation detected	The motor is blocked or not active.	Check the safety switch at the door for soiling. Clean the safety switch (if required with compressed air). If the error persists, please contact Fritsch Service.

Repairs

No.	Fault description	Cause	Remedy
Er11	Frequency converter signals no speed during operation detected	The motor is blocked or not active.	Clean the grinding chamber and the labyrinth seals (see Chapter 7.6 'Cleaning the labyrinth seal' on page 44 and Chapter 7.7 'Cleaning the labyrinth seal in the closing lid' on page 46). Check that the rotor moves freely. If necessary, add grinding stock more slowly and evenly.
Er12	STO safety connection faulty		Contact Fritsch Service!
Er13	STO safety switch-off faulty		Contact Fritsch Service!
Er14	STO – discrepancy error		Contact Fritsch Service!
Er15	Frequency converter	Does not signal readiness	Switch off the device for 30 seconds. Then switch the device back on again. If the error persists, contact Fritsch Service.
Er16	Frequency converter	No frequency converter connected	Contact Fritsch Service!
Er17	Frequency converter	Frequency converter temperature too high	Wait until the device has cooled down and restart it after several minutes. Clean the grinding chamber and the labyrinth seals (see Chapter 7.6 'Cleaning the labyrinth seal' on page 44 and Chapter 7.7 'Cleaning the labyrinth seal in the closing lid' on page 46). Check that the rotor moves freely. If necessary, add grinding stock more slowly and evenly.
Er18	Frequency converter	Speed is not reached	Switch off the device and clean the grinding chamber. Feed the grinding stock more slowly. Clean the grinding chamber and the labyrinth seals (see Chapter 7.6 'Cleaning the labyrinth seal' on page 44 and Chapter 7.7 'Cleaning the labyrinth seal in the closing lid' on page 46). Check that the rotor moves freely. If necessary, add grinding stock more slowly and evenly.
Er19	Frequency converter	Current limit reached	Switch off the device and clean the grinding chamber. Feed the grinding stock more slowly. Clean the grinding chamber and the labyrinth seals (see Chapter 7.6 'Cleaning the labyrinth seal' on page 44 and Chapter 7.7 'Cleaning the labyrinth seal in the closing lid' on page 46). Check that the rotor moves freely. If necessary, add grinding stock more slowly and evenly.
Er20	Frequency converter	No communication possible	Contact Fritsch Service!
Er21	Frequency converter	Signals error	Press the "SPEED/TIME" button to display the error code of the frequency converter. Contact Fritsch Service with this information.
Er22	Grinding chamber door	Opens during operation	Check that the mechanical door lock is fit correctly. If the error persists, please contact Fritsch Service.

10 Disposal

It is hereby confirmed that FRITSCH has implemented the directive 2002/95/EC of the European Parliament and Council from 27th January 2003 for the limitation of the use of certain dangerous substances in electrical and electronic devices.

FRITSCH has registered the following categories according to the German electrical and electronic equipment act, section 6, paragraph 1, clause 1 and section 17, paragraphs 1 and 2:

Mills and devices for the preparation of samples have been registered under category 6 for electrical and electronic tools (except for large stationary industrial tools).

Analytical devices have been registered under category 9, monitoring and control instruments.

It has been accepted that FRITSCH is operating only in the business-to-business area. The German registration number for FRITSCH is WEEE reg. no. DE 60198769

FRITSCH WEEE coverage

Since the registration of FRITSCH is classified for bilateral transactions, no legal recycling or disposal process is described. FRITSCH is not obliged to take back used FRITSCH devices.

FRITSCH declares it is prepared to take back used FRITSCH devices for recycling or disposal free of charge whenever a new device is purchased. The used FRITSCH device must be delivered free of charge to a FRITSCH establishment.

In all other cases FRITSCH takes back used FRITSCH devices for recycling or disposal only against payment.

11 Guarantee terms

Guarantee period

As manufacturer, FRITSCH GmbH provides – above and beyond any guarantee claims against the seller – a guaranty valid for the duration of two years from the date of issue of the guarantee certificate supplied with the device.

Within this guarantee period, we shall remedy all deficiencies due to material or manufacturing defects free of charge. Rectification may take the form of either repair or replacement of the device, at our sole discretion. The guarantee may be redeemed in all countries in which this FRITSCH device is sold with our authorisation.

Conditions for claims against the guarantee

This guarantee is subject to the condition that the device is operated according to the instructions for use / operating manual and its intended use.

Claims against the guarantee must include presentation of the original receipt, stating the date of purchase and name of the dealer, together with the complete device type and serial number.

For this guarantee to take effect, the answer card entitled "Securing of Guarantee" (enclosed with the device) must be properly filled out and despatched without delay after receipt of the device and be received by us within three weeks or alternatively, online registration must be carried out with the above-mentioned information.

Reasons for loss of the guarantee

The guarantee will not be granted in cases where:

- Damage has arisen due to normal wear and tear, especially for wear parts, such as: Crushing jaws, support walls, grinding bowls, grinding balls, sieve plates, brush strips, grinding sets, grinding disks, rotors, sieve rings, pin inserts, conversion kits, sieve inserts, bottom sieves, grinding inserts, cutting tools, sieve cassettes, sieve and measuring cell glasses.
- Repairs, adaptations or modifications were made to the device by unauthorized persons or companies.
- The device was not used in a laboratory environment and/or has been used in continuous operation.
- Damage is present due to external factors (lightning, water, fire or similar) or improper handling.
- Damage is present that only insubstantially affects the value or proper functioning of the device.
- The device type or serial number on the device has been changed, deleted, removed or in any other way rendered illegible
- The above-mentioned documents have been changed in any way or rendered illegible.

Costs not covered by the guarantee

This guarantee excludes any costs for transport, packaging or travel that accrue in the event the product must be sent to us or in the event that one of our specialist technicians is required to come to your site. Any servicing done by persons not authorised by us and any use of parts that are not original FRITSCH accessories and spare parts will void the guarantee.

Further information about the guarantee

The guarantee period will neither extend nor will a new period of guarantee begin in the event that a claim is placed against the guarantee.

Please provide a detailed description of the type of error or the complaint. If no error description is enclosed, we shall interpret the shipment as an assignment to remedy all recognisable errors or faults, including those not covered by the guarantee. Errors or faults not covered by the guarantee shall in this case be rectified at cost.

We recommend reading the operating manual before contacting us or your dealer, in order to avoid unnecessary inconvenience.

Ownership of defective parts is transferred to us with the delivery of the replacement part; the defective part shall be returned to us at buyer's expense.



NOTICE!

Please note that in the event that the device must be returned, the device must be shipped in the original Fritsch packaging. Fritsch GmbH denies all liability for any damage due to improper packaging (packaging not from Fritsch).

Any enquiries must include a reference to the serial number imprinted on the type plate.

12 Exclusion of liability

Before using the product, be sure to have read and understood this operating manual.

The use of the product requires technical knowledge; only commercial use is permitted.

The product may be used exclusively within the scope of applications set down in this operating manual and within the framework of guidelines put forth in this operating manual and must be subject to regular maintenance. In case of non-compliance, improper use or improper maintenance, the customer assumes full liability for the functional capability of the product and for damage or injury arising from violating these obligations.

The contents of this operating manual are subject in entirety to copyright law. This operating manual and its contents may not be copied, further distributed or stored in any form, in part or in whole, without the prior written consent of Fritsch.

This operating manual has been prepared to the best of our knowledge and checked for accuracy at the time of printing. FRITSCH GMBH assumes no guarantee or liability whatsoever for the accuracy or completeness of the contents of this operating manual, including but not limited to the implied warranties of merchantability and fitness for a particular purpose, unless liability is expressly prescribed by applicable laws or jurisprudence.

FRITSCH GMBH expressly reserves the right to modify and/or update this operating manual without prior notice. The same applies to modifications and improvements to the products described in this operating manual. It is the responsibility of the user to ensure that they have the current version of this operating manual. For more information, please contact your local FRITSCH GMBH distributor or Fritsch GmbH, Industriestr. 8, D-55473 Idar-Oberstein.

Not all parts shown here are necessarily installed in the product. The buyer is not entitled to delivery of these parts. If interested, please contact your local FRITSCH GMBH distributor or Fritsch GmbH, Industriestr. 8, D-55743 Idar-Oberstein.

FRITSCH GMBH takes the greatest care to ensure that the quality, reliability and safety of your products are continuously improved and adapted to the state of the art. The supplied products as well as this operating manual conform to the current state of the art when they leave the sphere of influence of FRITSCH GMBH.

By using the product the customer agrees with this and recognizes that defects, malfunctions or errors cannot be completely excluded. To prevent risk of damage to persons or property or of other direct or indirect damage, resulting from this or other causes, the customer must implement sufficient and comprehensive safety measures for working with the product.

Exclusion of liability

Fritsch GmbH excludes any liability, warranty, or other obligation to compensate for damages, regardless of whether this liability, warranty, or other obligation is explicit or implicit, contractual or arising from unlawful acts or prescribed contractually, by law, or otherwise. In no event shall the buyer be entitled to any compensation from Fritsch GmbH for any special, direct, indirect, coincidental or consequential damage, including but not limited to lost profits, lost savings, lost sales or financial loss of any kind or for compensation of third parties, for downtimes, for lost goodwill, for damage to or replacement of equipment and property, for costs or restoration of materials or goods related to the product or the use of our products, for other damage or injury to persons (including fatal injuries) or similar. The above exclusion of liability is limited by mandatory liability as prescribed by laws or jurisprudence. Liability for negligence is excluded in all cases.

No permission is given expressly, implicitly or otherwise for the use of patents, brands or other copyrights. We also assume no liability for copyright infringements or infringements of the rights of third parties arising from the use of this product.

Neither compliance with this operating manual nor the conditions and methods used during installation, operation, use and maintenance of the product can be monitored by Fritsch GmbH. Improper execution of the installation can result in property damage and thus endanger persons. Therefore, we assume absolutely no responsibility or liability for loss, damage or costs that result from errors at installation, improper operation or improper use or improper maintenance or are in any way connected to these.

14 Index

A	
Accident prevention	9
Authorised persons	9
B	
Basic structure	8
C	
Changing fixed knives	29
Changing the rotor	32
Changing the sieve cassette	33
Cleaning	41
Closing the cutting mill	34
Comminution procedures	35
Current draw	19
D	
Dimensions	17
Disposal	53
E	
Electrical connection	24
Electrical fuses	20
Exclusion of liability	56
Exhaust system	38
Explanation of signs	11
Explanation of symbols	11
F	
Fastening the Universal Cutting Mill	22
Final fineness	20
Funnel conversion	22
G	
Guarantee terms	54
H	
Hazardous points	16
M	
Mains voltage	18
Maintenance	48
Material	20
O	
Operating noise	18
Operating principle	10
Overload	36
Overload protection	16
P	
Power consumption	19
Protection against restart	16
Protective equipment	15
R	
Removing funnel parts	43
Requirements for the user	9
S	
Safety information	11
Safety logbook	58, 59
Setting the gap width	30
Setting up	21
Skilled workers	9
T	
Tooling Mode	32
Transport	21
U	
Unpacking	21
W	
Warning information	11
WEEE	53
Weight	17
Working with the mill	28



